



C-130 CAPABILITIES

THE POWER OF PARTNERSHIP



 Collins Aerospace	Collins Aerospace's primary landing-gear products include Duracarb Carbon Brake and Lock-Ring Wheel retrofit. IPT also stocks wheels, brakes, and components for your AOG needs.
	Extant Aerospace offers the Combined Altitude Radar Altimeter (CARA) System, AN/APN-232 Receiver Transmitter (RT) Height Indicator (HI) Signal Data Converter (SDC).
	Northrop Grumman offers the APN-241 Tactical Transport Radar Spares and Repairs.
	Woodward is a manufacturer of Speed Switch, Actuating Assy, Shaft Assy, Globe Valve for C-130 H and legacy. Rudder/ Aileron & Elevator Autopilot Servo, Prop Pitch Angle Transducer and Azimuth Drive for C-130 J.
	Turbopower, LLC is a Rolls Royce (RR) Authorized Maintenance Center (AMC) providing value-added repair and overhaul services to a worldwide fleet of military aircraft.
	PacSci EMC products ensure the proper initiation, sequencing, and function of aircraft safety systems such as Cartridge and Fire Extinguisher.
 AEROFLUIDPRODUCTS	Aero Fluid Products offers a variety of valves including hydraulic, engine, pneumatic, bleed air, anti-ice, pressure regulating, and fuel along with cabin pressure controls and electromechanical and linear actuators.
	Adams Rite Aerospace has over 80 years experience offering Control Wheel, Pilot Control Wheel Assy, Column Assy-Control, Flight Station (Pilot & Co-Pilot).
	Triumph specializes in the design, development, certification, manufacture and repair of fuel pumps, fuel metering units, fuel controls, and electronic engine control systems.
	Korry has been a trusted name in Light Assy, Indicator; Annunciators and Indicating Panel.
	Chemring Energetic Devices is the leading manufacturer of countermeasures and energetics as well as life support test equipment for air force and naval applications.
	EnerSys is a prominent enterprise engaged in the manufacturing and distribution of reserve power and motive power batteries, power equipment, and battery accessories.
	Acme Aerospace offers products such as the AMPS-2000 Emergency Backup Power supply.
	BAE Systems is a leading provider of ALE-47 Airborne Countermeasures Dispenser System, Testers, Memory Load Verifier, Threat Matrix Generator, C-130 Loadmaster Seat, Aircraft Armor Systems, Wall Style Aircraft Troop Seat and AN/ARC-164 Radio.
	ColumbusJACK/Regent supplies high-quality hydraulic jacks and lifting systems ensuring safe and efficient lifting, positioning, and maintenance of heavy equipment and structures.
	Hartwell is a leader for latches and flush catches including housing assembly, engine toggle assy, lock release lever, catch strike, mortise latch, lock trigger and more.
 Avionic Instruments	Avionic Instruments produces Regulated Transformer Rectifier Unit Model No. Rtr11200-1a, Aerovac Frequency Converter Model No. 4c3500-1a-Mv-2147 and Static Inverters.
	Aces Systems constructs VIPER-2E is a versatile yet compact instrument that combines all of the diverse technologies required for high-end engine vibration analysis, transient balance, fan trim balance, propeller balance and acoustic analysis into one tool.

RICARDO FLORES
BUSINESS DEVELOPMENT DIRECTOR
AMERICAS & SOUTH ASIA
ricardo@iptsb.com

TAY KAY LAI
BUSINESS DEVELOPMENT DIRECTOR
ASIA/PAC
tay@iptsb.com

MONICA SEMPERLOTTI
BUSINESS DEVELOPMENT DIRECTOR
EMEA
monica@iptsb.com

INTEGRATED PROCUREMENT TECHNOLOGIES
7230 HOLLISTER AVENUE
GOLETA, CA 93117 USA
P. 805 682 0842 F. 805 682 9434



C-130 WHEEL & BRAKE UPGRADE



Collins Aerospace



LOCK RING WHEEL (BOLTLESS)

P/N 3-1660
 NSN 1630-01-561-4960
 Lock Ring Design
 Service Proven on F-16 and C-5
 25,000 Mile Wheel Life

DURACARB® CARBON BRAKE

P/N 2-1744
 NSN 1630-01-561-4963
 Optimized 3-Rotor, 6 Piston Design
 2,000 Landings per Overhaul



FEATURE	BENEFIT
Faster Tire Change Time	80% reduced tire change time (52 vs. 255 min. for current wheel); Decreased maintenance time
Longer Wheel Life	6 times longer life (25,000 vs. 4,220 mile life for current wheel) Fewer wheel replacements; Increased operational usage
More Landings Per Overhaul	8 times longer life (2,000 vs. 250 LPO for current steel heatsink) Fewer brake replacements; Increased operational usage
Lighter Weight	17% lighter weight (270 vs 327lbs. for current wheel and brake) Increased payload; Reduced fuel cost
Lower Component Count	17% fewer parts (490 vs 587 for current wheel and brake) Reduced maintenance and logistics

One aircraft upgrade kit is required to support the installation of 4 Lock Ring Wheels and 4 Carbon brakes per aircraft (8-12 hours to complete wheel and brake upgrade).

P/N 380-180 Aircraft Upgrade Kit		
Part Number	Component Description	Qty in Kit
380-179	PARTS KIT-BRACKET	1
380-174	PARTS KIT - FLEXIBLE HOSE	1
380-175	PARTS KIT - HUB CAP	4
63-537	NUT	48
80-836	WASHER, PLAIN	48
43-1524	BOLT	48
M83485/1-908	O-RING,RUBBER	4
M83485/1-110	PACKING - PREFORMED	4
M83485/1-906	PACKING - PREFORMED	4
M83485/1-904	PACKING - PREFORMED	2

RICARDO FLORES
 BUSINESS DEVELOPMENT DIRECTOR
 AMERICAS & SOUTH ASIA
ricardo@iptsb.com

TAY KAY LAI
 BUSINESS DEVELOPMENT DIRECTOR
 ASIA/PAC
tay@iptsb.com

MONICA SEMPERLOTTI
 BUSINESS DEVELOPMENT DIRECTOR
 EMEA
monica@iptsb.com

INTEGRATED PROCUREMENT TECHNOLOGIES
 7230 HOLLISTER AVENUE
 GOLETA, CA 93117 USA
 P. 805 682 0842 F. 805 682 9434



RETROFIT CONSIDERATIONS



Hydraulic pressure available at the brakes (2,030 / 3,000 PSI) Brake control model and capability (Mk II / Mk IV)

C-130 MODEL	CARBON BRAKE	LOCK RING WHEEL	INSTALL KIT	3,000 PSI BRAKE METERING VALVE	Mk IV ANTI-SKID SYSTEM
J	4	4	1		
Legacy (pre-J)	4	4	1	2 *	2 **

* Some aircraft already have 3,000 PSI BMVs installed - 1985 (85-0003) and newer

** Recommended for best performance – required above 155,000 pounds

Stay with MK II Anti-Skid System

ITEM	P/N	NSN	QTY/AC	SUPPLIER
Carbon Brake	2-1744	1630-01-561-4963	4	COLLINS
Lock Ring Wheel	3-1660	1630-01-561-4960	4	COLLINS
Install Kit (Hoses, brackets, fasteners, etc.)	380-180	1630-01-622-0033	1	COLLINS
3,000 PSI Brake Metering Valve	23410-3	1630-00-998-7897	***	EATON
Mk II Anti-Skid System				
3,000 PSI MK II Controller	42-109A	1630-01-104-1015	***	CRANE

*** Some aircraft already have 3,000 PSI BMVs and Controllers installed

TIME COMPLIANT TECHNICAL ORDERS (TCTOS)	TECHNICAL ORDERS (TOS)
<p>Final Release October 2012</p> <p>TO 1C-130-2095</p> <p>Replacement of Mk II anti-skid system with Mk IV anti-skid system on C-130E/H aircraft</p> <p>TO 1C-130-2096</p> <p>Replacement of 2030 PSI brake metering valves (PN 23410 or 11060-7) with 3000 PSI brake metering valves (PN 23410-3 or 697395-1) on C-130E/H aircraft</p> <p>TO 1C-130-2098</p> <p>Installation of carbon brakes (PN 2-1744) and replacement wheels (PN 3-1660) on select C-130H aircraft</p>	<p>BRAKE</p> <p>Intermediate– 4B1-2-1342 Depot – 4B1-2-1323 Illustrated parts breakdown (IPB) – 4B1-2-1334</p> <p>WHEEL</p> <p>Intermediate – 4W1-3-1662 Depot – 4W1-3-1663 IPB – 4W1-3-1664</p>

RICARDO FLORES
 BUSINESS DEVELOPMENT DIRECTOR
 AMERICAS & SOUTH ASIA
ricardo@iptsb.com

TAY KAY LAI
 BUSINESS DEVELOPMENT DIRECTOR
 ASIA/PAC
tay@iptsb.com

MONICA SEMPERLOTTI
 BUSINESS DEVELOPMENT DIRECTOR
 EMEA
monica@iptsb.com

INTEGRATED PROCUREMENT TECHNOLOGIES
 7230 HOLLISTER AVENUE
 GOLETA, CA 93117 USA
 P. 805 682 0842 F. 805 682 9434

THE POWER OF PARTNERSHIP

C-130 LIGHTING SYSTEMS



PART NUMBER	DESCRIPTION	NSN
9HD409687-00	COVER,VEHICULAR LIGHT	6220-01-667-4779
2LA007585-50	LIGHT,DOME	6220 15094754
2LA 003 849 01	LIGHT,NAVIGATIONAL,AIRCRAFT	6220 13589974
2LA 003 849-00	LIGHT,NAVIGATIONAL,AIRCRAFT	6220 13589974
8ES 400 634-00	SEMICONDUCTOR DEVICE, THYRISTOR	5961 13610527
8ES 400 637-00	TRANSISTOR	5961 13610518
9ML707168-34	TRANSISTOR	5961 13610518
GEPS150-5	CAPACITOR,FIXED,METALLIZED, PAPER-PLASTIC DIELECTRIC	5910 11242436
9MJ401817-00	INSULATOR,PLATE	5970 13615067
2LA 007 585-30	LIGHT,DOME	6220 14395600
9EL409543-00	LENS,LIGHT	6210 15052789
9EL409543-05	LENS,LIGHT	6210 15052789
2LA007586-30	LIGHT,DOME	6220 14392772
8ES 400 633-00	SEMICONDUCTOR DEVICE,DIODE	5961 13610520
2LA 007 585-40	LIGHT,DOME	6220 14395608
8ES 401 269-00	TRANSISTOR	5961 13616402
2LA007585-50	LIGHT,DOME	6220 15094754
9ML 401 829-01	RELAY ASSEMBLY	5945 13600922
8ES 401 422-00	SEMICONDUCTOR DEVICE,DIODE	5961 13610525
8ES 401 425-01	TRANSISTOR	5961 13610519
8ES 400 320-00	TRANSISTOR	5961 13610517
2LA 007 519-30	LIGHT,DOME	6220 14393004
9HD409687-00	COVER,VEHICULAR LIGHT	6220 16674779
2LA 003 849-00	LIGHT,NAVIGATIONAL,AIRCRAFT	6220 12914266
2LA003849-00	LIGHT,NAVIGATIONAL,AIRCRAFT	6220 13589974
2LA 003 849 01	LIGHT,NAVIGATIONAL,AIRCRAFT	6220 13589974
8ES 005 164-01 P00	CONTROL,NAVIGATIONAL LIGHT	6220 13249002
8ES 005 164-02 M00	CONTROL,NAVIGATIONAL LIGHT	6220 13249002
8ES 005 164-02	CONTROL,NAVIGATIONAL LIGHT	6220 13249002
8ES003417-01	POWER SUPPLY	6130 12907512
6220-12-187-9698	POWER SUPPLY	6130 12907512
8 ES 003 417-00 M01	POWER SUPPLY	6130 12907512
8ES-003-417-00	POWER SUPPLY	6130 12907512
8ES 400 634-00	SEMICONDUCTOR DEVICE,THYRISTOR	5961 13610527
9XB 402 093-00	INSULATOR,BUSHING	5970 13615071
9ML 401 553-00	CAPACITOR,FIXED,ELECTROLYTIC	5910 13652401
9ML 401 847-00	REACTOR	5950 13605008
8ES 400 637-00	TRANSISTOR	5961 13610518
9GX 852 298-00	GASKET	5330 13599352
9MJ 401 817-00	INSULATOR,PLATE	5970 13615067

PART NUMBER	DESCRIPTION	NSN
402068-00	CONTACT,ELECTRICAL	5999 10363669
9NB402068-00	CONTACT,ELECTRICAL	5999 10363669
9HD 401 863-00	COVER,ACCESS	5340 13598824
9MJ 401 471-00	INSULATOR,BUSHING	5970 13615072
9NM 402 067-00	SOCKET,PLUG-IN ELECTRONIC COMPONENTS	5935 13605991
9MK 401 831-00	TRANSFORMER,POWER	5950 13605029
2LA 007 585-30	LIGHT,DOME	6220 14395600
A 007 585-30	LIGHT,DOME	6220 14395600
9ML 401 878-01	RESISTOR,FIXED,FILM	5905 13603945
9NS 401 720-02	SCREW,MACHINE	5305 13660422
9XB 046 627-00	INSULATOR,DISK	5970 13615066
9MJ 401 810-00	INSULATOR,PLATE	5970 13615068
8HG 401 121-00	CLAMP,LOOP	5340 13599386
2LA 007 586-30	LIGHT,DOME	6220 14392772
9MJ 400 641-00	INSULATOR,PLATE	5970 13615069
8ES 400 633-00	SEMICONDUCTOR DEVICE,DIODE	5961 13610520
A 007 585-40	LIGHT,DOME	6220 14395608
2LA 007 585-40	LIGHT,DOME	6220 14395608
402260-00	SWITCH,ROTARY	5930 123240012
8ES 401 269-00	TRANSISTOR	5961 13616402
9ML 401 829-01	RELAY ASSEMBLY	5945 13600922
9ML 401 829-00	RELAY ASSEMBLY	5945 13600922
8ES 401 422-00	SEMICONDUCTOR DEVICE,DIODE	5961 13610525
9ML 401 878-02	RESISTOR,FIXED,FILM	5905 13601439
9ML 401 865-00	CAPACITOR,FIXED,CERAMIC DIELECTRIC	5910 13645178
8JB 402 315-00	CONNECTOR,RECEPTACLE,ELECTRICAL	5935 13602899
9ML 401 415-05	RESISTOR,FIXED,COMPOSITION	5905 13603024
8ES 401 425-01	TRANSISTOR	5961 13610519
9ML 401 492-00	CAPACITOR,FIXED,ELECTROLYTIC	5910 13652400
8ES 400 320-00	TRANSISTOR	5961 13610517
9NM 401 389-02	NUT,PLAIN,PLATE	5310 13607509
8GH 007 429-28	LAMP,INCANDESCENT	6240 123448188
007429-28	LAMP,INCANDESCENT	6240 123448188
4RD 401 842-00	RELAY,ELECTROMAGNETIC	5945 13598834
9HD 402 153-00	PLATE,MOUNTING	5340 13607583
2LA 007 519-30	LIGHT,DOME	6220 14393004
2LA 003 849-00 M00	LIGHT,NAVIGATIONAL,AIRCRAFT	6220 12914266
6220-12-187-5292	LIGHT,NAVIGATIONAL,AIRCRAFT	6220 12914266
2LA003849-00	LIGHT,NAVIGATIONAL,AIRCRAFT	6220 12914266
2LA 003 849 00 M00	LIGHT,NAVIGATIONAL,AIRCRAFT	6220 12914266

RICARDO FLORES
BUSINESS DEVELOPMENT DIRECTOR
AMERICAS & SOUTH ASIA
ricardo@iptsb.com

TAY KAY LAI
BUSINESS DEVELOPMENT DIRECTOR
ASIA/PAC
tay@iptsb.com

MONICA SEMPERLOTTI
BUSINESS DEVELOPMENT DIRECTOR
EMEA
monica@iptsb.com

INTEGRATED PROCUREMENT TECHNOLOGIES
7230 HOLLISTER AVENUE
GOLETA, CA 93117 USA
P. 805 682 0842 F. 805 682 9434

THE POWER OF PARTNERSHIP



C-130

COMBINED ALTITUDE RADAR ALTIMETER



COMBINED ALTITUDE RADAR ALTIMETER (CARA) AN/APN-232

P/N 8010000653-6
NSN 5841-01-301-4588

- Standard radar altimeter on many USAF platforms
- Fully military-qualified system for severe operational environments
- Low Probability of Detection and Intercept
- High reliability
- Existing organization and intermediate level test and maintenance capabilities
- Fully established and committed depot logistics support
- Fully integrated with critical avionics systems
- Automatic Terrain Avoidance/Following (TA/TF) Systems
- Ground Collision/Proximity Avoidance/Warning Systems
- Terminal Collision Avoidance System (TCAS)

RECEIVER TRANSMITTER (RT)



HEIGHT INDICATOR (HI)



SIGNAL DATA CONVERTER (SDC)

WEIGHT	Receiver Transmitter (RT): 9.2 pounds
	Signal Data Converter (SDC): 1.9 pounds
	Indicator: 2.1 pounds
	Antenna: 0.3 pound each
DIMENSIONS	RT: 3.50 x 6.30 x 8.75 inches
	SDC: 9.48 x 6.30 x 0.82 inches
	Indicator: 3.25 x 3.25 x 4.10 inches
	Antenna: 4.0 x 4.0 x 0.21 inches

RICARDO FLORES
BUSINESS DEVELOPMENT DIRECTOR
AMERICAS & SOUTH ASIA
ricardo@iptsb.com

TAY KAY LAI
BUSINESS DEVELOPMENT DIRECTOR
ASIA/PAC
tay@iptsb.com

MONICA SEMPERLOTTI
BUSINESS DEVELOPMENT DIRECTOR
EMEA
monica@iptsb.com

INTEGRATED PROCUREMENT TECHNOLOGIES
7230 HOLLISTER AVENUE
GOLETA, CA 93117 USA
P. 805 682 0842 F. 805 682 9434



C-130 CAPABILITIES



NORTHROP GRUMMAN APN-241

TACTICAL TRANSPORT RADAR

Northrop Grumman's AN/APN-241 radar delivers game changing mission capability to the transport community worldwide, supporting both military and humanitarian missions.

IPT represents all repairs and FN spares sales of the APN-241 Radar, Northrop is the sole source for repairs, there are no other authorized repair centers.

DESCRIPTION	C-130H	C-130J
RECEIVER TRANSMITTER PROCESSOR	780R290G06 780R290G07 780R290G08 780R290G09	780R270G10 780R270G13
RECEIVER TRANSMITTER PROCESSOR MOUNT	780R164G03	780R164G03
ANTENNA	788R330G01	788R330G01
RADAR TARGET INDICATOR (NAV DISPLAY)	780R401G01	N/A
DATA ENTRY JOYSTICK (CURSOR CONTROL)	780R406G01	N/A
RADAR SET CONTROL (PILOT CTRL PANEL)	780R404G01	N/A
RADAR SET CONTROL (NAV CTRL PANEL)	780R405G03	N/A
RADAR SET CONTROL (PILOT DISPLAY CTRL PANEL)	780R402G03	N/A



RICARDO FLORES
BUSINESS DEVELOPMENT DIRECTOR
AMERICAS & SOUTH ASIA
ricardo@iptsb.com

TAY KAY LAI
BUSINESS DEVELOPMENT DIRECTOR
ASIA/PAC
tay@iptsb.com

MONICA SEMPERLOTTI
BUSINESS DEVELOPMENT DIRECTOR
EMEA
monica@iptsb.com

INTEGRATED PROCUREMENT TECHNOLOGIES
7230 HOLLISTER AVENUE
GOLETA, CA 93117 USA
P. 805 682 0842 F. 805 682 9434



C-130 CAPABILITIES



CAGE CODE	P/N	DESCRIPTION	NSN
66503	9901-300	SPEED SWITCH	2915-00-464-6946
66503	9901-301	SPEED SWITCH	2915-00-464-6938
66503	9901-507	ACTUATING ASSEMBLY	2915-00-588-8904
66503	9901-502	SHAFT ASSEMBLY	2915-00-715-8327
81873	1085350-7	SERVO VALVE	1650-00-055-6906
81873	26800	GLOBE VALVE	4820-00-529-4689
19710	3350370-3	RUDDER AUTOPILOT SERVO (C-130J)	6615-01-435-1133
19710	3350371-3	AILERON AUTOPILOT SERVO (C-130J)	6615-01-435-1138
19710	3350372-3	ELEVATOR AUTOPILOT SERVO (C-130J)	5990-01-434-7503
19710	3A1273A	PROPELLER PITCH ANGLE TRANSDUCER (C-130J)	6695-01-475-6213
19710	PJH201B	AZIMUTH DRIVE (C130J)	3010-01-445-6130
19710	PJH202A	AZIMUTH DRIVE (C-130J)	6105-01-445-9794
19710	PJH203	AZIMUTH DRIVE (C-130J)	N/A

FACTORY NEW PARTS

- IPT provides OEM-certified parts factory new from Woodward
- Every part comes with OEM Certificate of Conformance (COC)
- IPT provides guaranteed OEM pricing

REPAIR PROGRAM

- IPT is responsible for quoting repair and managing all required logistics, including export license
- Woodward performs all repairs using most recent engineering updates and proprietary technology
- Repair is covered by standard 12 month warranty
- MTBF is increased providing operator w/ increased aircraft availability

RICARDO FLORES
BUSINESS DEVELOPMENT DIRECTOR
AMERICAS & SOUTH ASIA
ricardo@iptsb.com

TAY KAY LAI
BUSINESS DEVELOPMENT DIRECTOR
ASIA/PAC
tay@iptsb.com

MONICA SEMPERLOTTI
BUSINESS DEVELOPMENT DIRECTOR
EMEA
monica@iptsb.com

INTEGRATED PROCUREMENT TECHNOLOGIES
7230 HOLLISTER AVENUE
GOLETA, CA 93117 USA
P. 805 682 0842 F. 805 682 9434

THE POWER OF PARTNERSHIP



C-130

REPAIR AND OVERHAUL CAPABILITIES



T-56 ENGINE

Turbopower, LLC is a Rolls Royce (RR) Authorized Maintenance Center (AMC) providing value-added repair and overhaul services to a worldwide fleet of military, commercial, and corporate-owned aircraft.

- RR Authorized Maintenance Center
- FAA Certified Repair Station for engine components, QEC's, APU and accessories
- Extensive components repair catalogue
- QEC Repair facility with independent sheet metal, electrical and paint capabilities
- SO9001: 2015/ EASA Certified
- T56/501D: RR AMC, engine and module repair and overhaul, testing, component repair, and technical services
- QEC: C-130/P-3/L-100 QEC Repair Center, 40,000 sq. ft. facility for QEC repairs and Non Destructive Testing (NDT)

CAGE CODE	P/N
Series I	T56-A-9C, D
	T56-A-11B
Series II	T56-A-7A, B
	T56-A-10WA
Series III	T56-A-14, LFE
	T56-A-15, LFE
	T56-A-16
	T56-A-423, 425

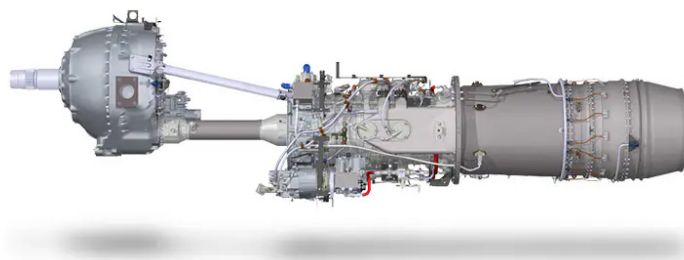

RICARDO FLORES
 BUSINESS DEVELOPMENT DIRECTOR
 AMERICAS & SOUTH ASIA
ricardo@iptsb.com

TAY KAY LAI
 BUSINESS DEVELOPMENT DIRECTOR
 ASIA/PAC
tay@iptsb.com

MONICA SEMPERLOTTI
 BUSINESS DEVELOPMENT DIRECTOR
 EMEA
monica@iptsb.com

INTEGRATED PROCUREMENT TECHNOLOGIES
 7230 HOLLISTER AVENUE
 GOLETA, CA 93117 USA
 P. 805 682 0842 F. 805 682 9434

C-130 CAPABILITIES

CARTRIDGE, FIRE EXTINGUISHER

P/N 4199-1

NSN 1377-00-677-6281

This Pressure Cartridge is an electro explosive device with an 18AWG insulated leadwire per MIL-W-16878 Type C. Upon application of firing current, the bridgewire explosive prime charge is activated igniting the main charge producing a nominal pressure of 3,250 psi in a 3 cc volume.

PERFORMANCE DATA:

NO-FIRE	.5 amp maximum
ALL-FIRE POWER	18 volts minimum at bridgewire
ALL-FIRE	1.5 amps minimum
BRIDGEWIRE RESISTANCE	1 ± .07 ohms
CONTINUITY CURRENT	.2 amp maximum; for repeated checkout .012, amp recommended
INSTALLATION TORQUE	55 ± 5 inch pounds
PRESSURE OUTPUT	2,500 to 4,000 psig in 3 cc volume
TIME FROM APPLICATION OF 18 VOLTS TO PEAK PRESSURE	15 milliseconds maximum
OPERATING TEMPERATURE RANGE	-65°F to +160°F
OPERATING ALTITUDE	50,000 feet maximum
LEADWIRE TO WITHSTAND	20 pound pull on terminal



18 AWG STRANDED, VINYL INSULATED (GREEN)
LEADWIRE, PER MIL-W-16878, TYPE C

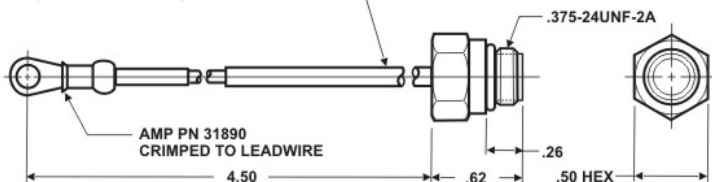

RICARDO FLORES
BUSINESS DEVELOPMENT DIRECTOR
AMERICAS & SOUTH ASIA
ricardo@iptsb.com

TAY KAY LAI
BUSINESS DEVELOPMENT DIRECTOR
ASIA/PAC
tay@iptsb.com

MONICA SEMPERLOTTI
BUSINESS DEVELOPMENT DIRECTOR
EMEA
monica@iptsb.com

INTEGRATED PROCUREMENT TECHNOLOGIES
7230 HOLLISTER AVENUE
GOLETA, CA 93117 USA
P. 805 682 0842 F. 805 682 9434



C-130 CAPABILITIES



AEROFLUIDPRODUCTS

PART NUMBER	DESCRIPTION	NSN
13F32	DISK ASSY, BRAKE	6105-00-757-3613
15F2	FILTER, RADIO FREQUENCY INTERFERENCE	5915-00-921-3375
2624125-1	GEAR, SPUR	3020-01-289-5594
2624126-1	GEAR, INTERNAL	3020-01-281-8602
2624127-1	PROGRAMMER	5865-01-437-3373
4298127-1	WIRE ROPE ASSEMBLY, SINGLE LEG	4010-01-513-4701
5145-00-1	VALVE, FLOW CONTROL	4810-01-472-1429
7173-286	SPACER, STRAIGHT	5365-01-519-6713

RICARDO FLORES
BUSINESS DEVELOPMENT DIRECTOR
AMERICAS & SOUTH ASIA
ricardo@iptsb.com

TAY KAY LAI
BUSINESS DEVELOPMENT DIRECTOR
ASIA/PAC
tay@iptsb.com

MONICA SEMPERLOTTI
BUSINESS DEVELOPMENT DIRECTOR
EMEA
monica@iptsb.com

INTEGRATED PROCUREMENT TECHNOLOGIES
7230 HOLLISTER AVENUE
GOLETA, CA 93117 USA
P. 805 682 0842 F. 805 682 9434

PART NUMBER	DESCRIPTION	NSN
8377-3	SCREW, ADJUSTING, SUP	1680-01-270-7661
880124	FOLLOWER, JACKSCREW	1680-00-686-1863
880125	STOP, ACTUATOR	1680-00-686-1864
880131	CLUTCH ASSEMBLY	2530-01-097-2227
880132	GEAR, SPUR	3020-00-758-6346
880137	PIN, STRAIGHT, HEADLESS	5315-01-315-0870
880140	GEAR CLUSTER	3020-01-127-0507
880141	GEAR, SPUR	3020-00-686-1866
880154-1	SPACER, SLEEVE	5365-00-762-2938
880173	WASHER	5310-01-109-2686
880191-1	WORMSHAFT, ACTUATOR	1680-01-417-3456
880193-1		
880199	PARTS KIT, ACTUATOR	1680-00-686-1880
880204-3	FILTER SUBASSEMBLY	5915-01-416-8113
880T100-3	ACTUATOR, ELECTRO-MECHANICAL, LINEAR	1680-01-329-7411
880T100R	ACTUATOR, ELECTRO-MECHANICAL, LINEAR	1680-00-073-8204
A3-093X500	PIN	
A3-093X625	PIN	
TS1000-42		
304A-143GC	BAL-SEAL	
328872		
502606	SPRING, HELICAL, COMPRESSION	5360-00-680-4670
502618	WASHER FLAT	5310-01-160-3975
731303	BODY, LOWER	2915-01-035-7702
731701	SOLENOID, ELECTRICAL	5945-00-933-8654
765000	SUPPRESSOR, SURGE	1680-00-073-0841
765012-11		
9440-11	WINCH, AIRCRAFT MOUNTED	1680-01-385-3219

C-130 CONTROL WHEEL UPGRADE



Adams Rite Aerospace

PART NUMBER	DESCRIPTION	NSN
1902-7	CONTROL WHEEL, AIRCRAFT	1680-00-673-8818
1902-8	CONTROL WHEEL, AIRCRAFT	1680-00-674-7581
1902-9	CONTROL WHEEL, AIRCRAFT	1680-00-707-7134
1902-10	CONTROL WHEEL, AIRCRAFT	1680-00-706-0101
53263-1	WHEEL ASSY - PILOT CONTROL	1680-01-483-3242
53263-2	CONTROL WHEEL, AIRCRAFT	1680-01-483-3244
53263-5		
53263-6		
53263-7	CONTROL WHEEL, PILOT	1680-01-483-3242
53263-8	CONTROL WHEEL, CO-PILOT	1680-01-483-3244
3350972-5	COLUMN ASSY-CONTROL, FLIGHT STATION (PILOT)	1680-01-439-3987
3350972-6	COLUMN ASSY-CONTROL, FLIGHT STATION (CO-PILOT)	1680-01-439-3988

WE ALSO OFFER FN & REPAIR COLUMN ASSEMBLIES

- P/N 3350972-5 includes P/N 53263-7 Control Wheel, Pilot
- P/N 3350972-6 includes P/N 53263-8 Control Wheel, Co-Pilot



REPAIR PROGRAM

- TTE included in repair price once repair is performed
- Switches to be replaced (this varies based on evaluation)
 - a) Transducer
 - b) Trim Switch
 - c) Rocker Switches (2 pcs)
- Wire harness and insulation replaced entirely
- All repairs are performed after the TTE report and FFP quote is approved by the customer
- Acceptance Test Procedure (ATP) is performed on a complete repaired wheel
- Normal Repair TAT 30 days (after customer approval of quote)
- Repair Warranty is 12 months from invoice date

RICARDO FLORES
BUSINESS DEVELOPMENT DIRECTOR
AMERICAS & SOUTH ASIA
ricardo@iptsb.com

TAY KAY LAI
BUSINESS DEVELOPMENT DIRECTOR
ASIA/PAC
tay@iptsb.com

MONICA SEMPERLOTTI
BUSINESS DEVELOPMENT DIRECTOR
EMEA
monica@iptsb.com

INTEGRATED PROCUREMENT TECHNOLOGIES
7230 HOLLISTER AVENUE
GOLETA, CA 93117 USA
P. 805 682 0842 F. 805 682 9434

CAPABILITIES: HANDLES & SWITCHES

PART NUMBER	DESCRIPTION	NSN
1401	HANDLE	5340-00-672-9842
2358	GRIP, HANDLE	5340-01-504-4298
1102-3	HANDLE, BOW	5340-00-634-7793
AR69	HANDLE, DOOR	1680-00-787-1254
AR70	HANDLE	5340-00-597-3140
612115-2	SWITCH	
612115-4	SWITCH	
51183	LATCH ASSEMBLY, AIRCRAFT	1560-01-550-5652
67749	HANDLE UNIT, DOOR	1680-01-550-8497
5700-2	BRAKE ASSY., DRAG, SPO (C/KC-130)	1680-00-707-5075
69565	COVER	
69829	BLUE SWITCH	
32011-11	SWITCH, PUSH BUTTON	
4532-3	HANDLE, DOOR	
53234-11	JOYSTICK, DATA ENTRY	
69566-3	TRIGGER GUARD MACHING	



RICARDO FLORES
BUSINESS DEVELOPMENT DIRECTOR
AMERICAS & SOUTH ASIA
ricardo@iptsb.com

TAY KAY LAI
BUSINESS DEVELOPMENT DIRECTOR
ASIA/PAC
tay@iptsb.com

MONICA SEMPERLOTTI
BUSINESS DEVELOPMENT DIRECTOR
EMEA
monica@iptsb.com

INTEGRATED PROCUREMENT TECHNOLOGIES
7230 HOLLISTER AVENUE
GOLETA, CA 93117 USA
P. 805 682 0842 F. 805 682 9434



C-130 ENGINE FUEL HEATER



The Fuel Heater is engine-mounted with fluid connections to both the engine fuel supply system and the engine lube oil system. The heater provides fuel heating for fuel de-icing, using engine lube oil flow during aircraft cold start and cold operation periods.

TTS P/N	ALT P/N	DESCRIPTION	NSN
UA524240	695810-3	FUEL HEATER	2915-00-789-1102

REPAIR PROGRAM

- Triumph has the expertise only the OEM can offer
- OEM repairs are more dependable, increase MTBF and cost less long-term
- Repair price is all inclusive
- TAT 45 days approx



RICARDO FLORES
 BUSINESS DEVELOPMENT DIRECTOR
 AMERICAS & SOUTH ASIA
ricardo@iptsb.com

TAY KAY LAI
 BUSINESS DEVELOPMENT DIRECTOR
 ASIA/PAC
tay@iptsb.com

MONICA SEMPERLOTTI
 BUSINESS DEVELOPMENT DIRECTOR
 EMEA
monica@iptsb.com

INTEGRATED PROCUREMENT TECHNOLOGIES
 7230 HOLLISTER AVENUE
 GOLETA, CA 93117 USA
 P. 805 682 0842 F. 805 682 9434



C-130 CAPABILITIES



HIGHER ASSEMBLIES

P/N	DESCRIPTION	NSN
276-5324-005	LIGHT ASSEMBLY, INDICATOR	6220-01-362-3720
276-5324-006	LIGHT ASSEMBLY, INDICATOR	6220-01-261-0280
276-5326-001	INDICATOR LIGHT ASSEMBLY	6615-01-101-1885
276-5328-001	PANEL, INDICATING LIGHT TRANSMITTING	6220-01-195-2560
12085-002	ANNUNCIATOR	6340-01-440-0853
12085-003	ANNUNCIATOR	6340-01-436-1129



INDIVIDUAL COMPONENTS

NSN (NON-NVIS)	NSN (NVIS)	KORRY PN (NON-NVIS)	KORRY PN (NVIS)	DESCRIPTION (NOMENCLATURE)
6210-00-873-6549	6210-01-321-5888	ST260HL6-4	12096-039	LIQUID OXYGEN LOW LIGHT
6210-00-143-6596	6210-01-329-8739	MS25041-8	---	
6210-00-143-6608	6210-01-329-8739	MS25041-8, -4 CAP	---	DFDR VOICE RECORDER WARNING LIGHT, IFF CAUTION LIGHT YELLOW (E/H1)
6210-00-299-4104	6210-01-432-8395	MS25331-6	---	ANTI-ICE OVERHEAT LIGHT (E/H1), JUMP LIGHT (RED)
6210-00-726-0790	6210-01-433-8689	MS25331-7	---	GREEN NO-ICE LIGHT, JUMP LIGHT (GREEN)
6210-00-710-4375	6210-01-438-1543	MS25010B13A	---	TRANSLUCENT ROSEBUD, NACELLE OVERHEAT PLACARD
6210-00-859-8934	6210-01-457-1210	ST260HL6-5	12096-041	BEAM COUPLER OFF LIGHT(E-4 AUTOPILOT)
6210-00-811-7134	6210-01-457-1211	ST260HL6-1	12096-048	MASTER FIRE WARNING
6210-00-860-1205	6210-01-462-4633	ST260HL6-6	12096-040	AUTO PILOT OFF LIGHT(E-4 AUTOPILOT)
6210-00-581-9467	6220-01-414-7758	ST136ML5-7	12095-007	CAP INDICATOR LH AC OFF LIGHT
NONE	6220-01-316-8346	ST260HL1-4	12096-038	MASTER DOOR OPEN LIGHT
6210-00-812-5967	6220-01-317-1159	ST136ML5-20	12095-097	#1 FUEL CORRECTION LIGHT, #1 PROP LOW OIL LIGHT (H2)
6210-00-812-5968	6220-01-317-1160	ST136ML5-21	12095-098	#2 FUEL CORRECTION LIGHT, #2 PROP LOW OIL LIGHT (H2)
6210-00-812-5969	6220-01-317-1161	ST136ML5-22	12095-099	#3 FUEL CORRECTION LIGHT, #3 PROP LOW OIL LIGHT (H2)
6210-00-812-5970	6220-01-317-1162	ST136ML5-23	12095-100	#4 FUEL CORRECTION LIGHT, #4 PROP LOW OIL LIGHT (H2)
6210-00-860-1206	6220-01-317-1163	ST136ML5-34	12095-153	MARKER BEACON "O" LIGHT
6210-00-060-5919	6220-01-317-1165	ST136ML5-39	12095-108	MARKER BEACON "A" LIGHT
6210-00-061-1479	6220-01-317-8031	ST136ML5-40	12095-109	MARKER BEACON "I" LIGHT
6210-00-865-7134	6220-01-320-2572	A7165-4	---	LAMP HOLDER

RICARDO FLORES
BUSINESS DEVELOPMENT DIRECTOR
AMERICAS & SOUTH ASIA
ricardo@iptsb.com

TAY KAY LAI
BUSINESS DEVELOPMENT DIRECTOR
ASIA/PAC
tay@iptsb.com

MONICA SEMPERLOTTI
BUSINESS DEVELOPMENT DIRECTOR
EMEA
monica@iptsb.com

INTEGRATED PROCUREMENT TECHNOLOGIES
7230 HOLLISTER AVENUE
GOLETA, CA 93117 USA
P. 805 682 0842 F. 805 682 9434

NSN (NON-NVIS)	NSN (NVIS)	KORRY P/N (NON-NVIS)	KORRY P/N (NVIS)	DESCRIPTION (NOMENCLATURE)
6210-00-865-7137	6220-01-321-7319	ST136ML5-28	12095-101	FUEL LOW PRESSURE LIGHTS
6210-00-859-8930	6220-01-321-7321	ST136ML5-30	12095-103	AUXILIARY TANK EMPTY LIGHT
6210-00-859-8929	6220-01-321-7322	ST136ML5-31	12095-104	EXTERNAL TANK EMPTY LIGHT
6210-00-434-4828	6220-01-321-7324	ST136ML5-46	12095-111	GENERATOR DISCONNECT FIRED LIGHT
6210-00-904-1697	6220-01-321-7325	ST136ML5-38	12095-107	ADS DOOR OPEN LIGHT
6210-00-299-4104	6220-01-323-9267	MS25331-6	---	AIR DEFLECTOR DOOR OPEN, SECONDARY FUEL PUMP PRESSURE LIGHT (E, H1)
6210-00-060-8788	6220-01-324-9927	ST136ML5-65	12095-117	CAP INDICATOR ISOL DC ON BATT LIGHT (E)
6210-01-014-8614	6220-01-329-4590	515-5432-001	---	SKE CAUTION LIGHT
6210-01-110-3716	6220-01-340-6466	ST260-HL6-29	12096-043	ALTITUDE LOW LIGHT
6210-00-946-2967	6220-01-340-9163	ST260HL-6-14	12096-047	IFF CAUTION LIGHT (H2)
6210-00-854-6464	6220-01-381-1771	ST136ML5-36	12095-160	ENGINE LOW OIL MASTER LIGHT
6220-00-299-7166	6220-01-395-5197	15-0007-1	---	C4 UTILITY LIGHT
6220-00-349-9294	6220-01-395-5197	MS17245-5A	---	C4 UTILITY LIGHT
6210-00-722-6455	6220-01-399-3656	MS25331-8	---	ANTI-SKID INOP, HYDRAULIC LOW PRESSURE LIGHT (E/H1)
6210-00-403-8082	6220-01-414-5254	ST136ML5-49	12095-049	BATT DISCH LIGHT (H1/H2)
6210-01-071-0884	6220-01-414-5257	ST136ML5-68	12095-068	CTR WING ANTI-ICE OVERHEAT LIGHT (H2)
6210-01-071-0885	6220-01-414-5258	ST136ML5-69	12095-069	WHEEL WELL ANTI-ICE OVERHEAT LIGHT (H2)
6210-01-071-0886	6220-01-414-5259	ST136ML5-70	12095-070	NOSE WHEEL WELL ANTI-ICE OVERHT LT (H2)
6220-01-338-9507	6220-01-414-5260	ST136ML5-71	12095-071	PITOT HEAT OFF LIGHT (H2)(ROSEMOUNT PITOT SYSTEM)
6210-01-103-1848	6220-01-414-5261	ST136ML5-58	12095-061	MARKER BEACON "A/I" LIGHT
6210-01-071-0883	6220-01-414-5262	ST136ML5-67	12095-067	OUTER WING ANTI-ICE OVERHEAT LIGHT (H2)
6210-00-005-7158	6220-01-414-6778	ST2602HL6-18	12096-018	SEC'Y FUEL PUMP PRESS/STRT VALVE OPEN (H2)
6210-00-581-9466	6220-01-414-7031	ST136ML5-16	12095-016	SELECT PWR OUT LIGHT
6210-00-581-9468	6220-01-414-7757	ST136ML5-6	12095-006	CAP INDICATOR RH AC OFF LIGHT
6210-00-583-3868	6220-01-414-7759	ST136ML5-8	12095-008	CAP INDICATOR ESS AC OFF LIGHT
6210-00-581-9464	6220-01-414-7760	ST136ML5-12	12095-009	CAP INDICATOR MAIN DC OFF LIGHT
6210-00-581-9469	6220-01-414-7762	ST136ML5-5	12095-005	GENERATOR OUT LIGHT
6210-00-581-9463	6220-01-414-7766	ST136ML5-11	12095-011	CAP INDICATOR ESS DC OFF LIGHT
6210-00-583-3869	6220-01-414-7767	ST136ML5-9	12095-012	CAP INDICATOR MAIN AC OFF LIGHT
6210-00-553-1076	6220-01-431-5120	MS25041-7	---	ANTISKID LIGHT LENS
6210-00-854-6463	6220-01-434-0160	ST136ML5-37	12095-161	PROP LOW OIL MASTER LIGHT
6210-01-071-0881	6220-01-450-3365	ST136ML5-45	12095-112	MARKER BEACON "M" LIGHT
6210-00-519-2653		MS25010B11A	---	TRANSLUCENT ROSEBUD, MASTER FIRE PLACARD
6210-00-710-4375	6220-01-454-6438	MS25010B13A	---	TRANSLUCENT ROSEBUD, NACELLE OVERHEAT PLACARD
6210-00-557-8967	6220-01-454-6440	ST136ML5-4	12095-166	#4 ENGINE NACELLE OVERHEAT LIGHT
6210-00-557-8968	6220-01-454-6441	ST136ML5-3	12095-165	#3 ENGINE NACELLE OVERHEAT LIGHT
6210-00-557-8970	6220-01-454-6443	ST136ML5-1	12095-163	#1 ENGINE NACELLE OVERHEAT LIGHT
6210-00-809-4377	6220-01-454-6446	ST136ML5-2	12095-164	#2 ENGINE NACELLE OVERHEAT LIGHT
6240-00-155-7836	6240-01-340-6497	MS25237-327	17597-003, -002, -001	LIGHT BULB "327" (WHITE/CLEAR), (RED), YELLOW)
6220-00-539-8769	5855-01-409-1790	A4513-8	---	JUMP LIGHT CAUTION YELLOW
6220-00-519-2156	5855-01-409-1792	A4513-9	---	JUMP LIGHT GO GREEN
6210-00-726-0790	6210-01-433-8689	MS25331-7	---	RAMP POSITION AIR DROP LIGHT
6220-00-544-6501	6220-01-371-0387	A-5395	---	CARGO DOOR UP LOCK INSPECTION LIGHT HOUSING
6220-00-544-6501	6220-01-371-0387	A-5395, S1228	---	JUMP PLATFORM HOOD
6210-00-686-4999	6220-01-438-5949	MS25331-2	---	DOOR OPEN LIGHT
5998-00-422-2599	6220-01-439-3004	362462-1	---	CARGO DOME LIGHT (R&R WHITE/RED TO WHITE/NVIS GREEN)
6220-00-583-3085	6220-01-478-7326	MS25219-13, -14	---	BEAVER TAIL LIGHT LENS

RICARDO FLORES
 BUSINESS DEVELOPMENT DIRECTOR
 AMERICAS & SOUTH ASIA
ricardo@iptsb.com

TAY KAY LAI
 BUSINESS DEVELOPMENT DIRECTOR
 ASIA/PAC
tay@iptsb.com

MONICA SEMPERLOTTI
 BUSINESS DEVELOPMENT DIRECTOR
 EMEA
monica@iptsb.com

INTEGRATED PROCUREMENT TECHNOLOGIES
 7230 HOLLISTER AVENUE
 GOLETA, CA 93117 USA
 P. 805 682 0842 F. 805 682 9434



C-130 CAPABILITIES

Chemring Energetic Devices

The upgraded System Communication and Oxygen Tester (SCOT) integrates several required items of test equipment into a single, portable, rugged, self-contained test unit. The SCOT equals or exceeds the USAF requirements for today's helmets, masks, Chemical Defense, Anti-G Garments, associated oxygen connections, and communication systems. This test equipment eliminated the need for high-pressure oxygen cylinders, hazardous materials, and it will significantly reduce supporting man-hours, deployment costs, and mobility footprint.

The SCOT is fully operational and in use by AFSOC, AFRC, AETC, ACC, AMC, and ANG throughout the world. This tester replaces test equipment such as the MQ-1, MH-2, and DMH-1. It is portable, self-contained, and USAF approved.

CAGE CODE	P/N	DESCRIPTION	NSN
93455	6112300-1	TEST STAND, AIRCRAFT OXYGEN SYSTEM	4920-01-691-9686

FEATURES

- Menu driven automated testing
- Portable
- Unrestricted transport on military aircrafts
- Eliminated the need for multiple test sets
- Self-contained, no bottled gas required
- Software upgradeable
- Performs helmet/mask fitting and troubleshooting
- Microphone and earphones testing
- Performs G-suit leak testing
- Provides proper pressure and flows to enable complete functional testing or aircrew life support equipment
- Designed for in-shop, field and deployments
- Rugged, proven design

SPECIFICATIONS

- Case - test equipment case with removable hinged cover
- Size - 15.06"L x 12.61"W x 13.25"H
- Weight - 39 lbs. max
- Power - 108-132VAC/216-264VAC



RICARDO FLORES
BUSINESS DEVELOPMENT DIRECTOR
AMERICAS & SOUTH ASIA
ricardo@iptsb.com

TAY KAY LAI
BUSINESS DEVELOPMENT DIRECTOR
ASIA/PAC
tay@iptsb.com

MONICA SEMPERLOTTI
BUSINESS DEVELOPMENT DIRECTOR
EMEA
monica@iptsb.com

INTEGRATED PROCUREMENT TECHNOLOGIES
7230 HOLLISTER AVENUE
GOLETA, CA 93117 USA
P. 805 682 0842 F. 805 682 9434

THE POWER OF PARTNERSHIP

C-130 MAIN BATTERY



All EnerSys Hawker aviation battery products are classified as non-hazardous and unrestricted for land, sea or air transportation when correctly packed. This battery needs very little maintenance, has no memory effect, and doesn't suffer from fading. Depending on application, operation and use, the battery can last up to 5 years allowing a fit-and-forget installation. Maintenance, when required, is simple and quick; only a visual inspection and a capacity test are needed. Thus a dedicated lead-acid battery shop is not required, as the batteries can be serviced in a NiCd shop.

APPLICATION	PART NUMBER	NSN	SPEC
C-130 ELCON CONNECTOR	F0777-3021	6140-01-266-1633	MIL D8565/5-1
C-130 CANNON CONNECTOR	F0777-3022	6140-01-266-1634	MIL D8565/5-2

ADVANTAGES

- Dispatched from the manufacturer's factory fully charged
- Inspection free storage life of 2 years when stored at or under 25°C (77°F)
- Completely sealed and virtually maintenance-free
- Fully supports aerobatic operations
- Long life, pure lead grids
- Recovers from deep discharge
- Vents and thermal sensors not required
- Easy commissioning, normally consisting of only a voltage check
- Classified as non-hazardous and unrestricted for transportation when correctly packed.



RICARDO FLORES
BUSINESS DEVELOPMENT DIRECTOR
AMERICAS & SOUTH ASIA
ricardo@iptsb.com

TAY KAY LAI
BUSINESS DEVELOPMENT DIRECTOR
ASIA/PAC
tay@iptsb.com

MONICA SEMPERLOTTI
BUSINESS DEVELOPMENT DIRECTOR
EMEA
monica@iptsb.com

INTEGRATED PROCUREMENT TECHNOLOGIES
7230 HOLLISTER AVENUE
GOLETA, CA 93117 USA
P. 805 682 0842 F. 805 682 9434

THE POWER OF PARTNERSHIP



C-130 POWER SUPPLY



Acme Aerospace Inc.

AMPS-2000 EMERGENCY BACKUP POWER SUPPLY

P/N 154BS101-1
NSN 6130-01-436-0627

Acme Aerospace has over 30 years of experience in the custom design and manufacturing of aviation and aerospace battery systems and similar support products. Acme established itself as a leader in emergency backup batteries with the release of its Airborne Modular Power Supply (AMPS). The AMPS family leveraged off the reduced weight of sealed Nickel Cadmium cells coupled with an internal charger and controller.

Typically selected in applications where duty cycle and weight were critical, Acme has produced an excess of 5,000 units. The AMPS-2000 supplies 200 watts for 30 minutes.



RICARDO FLORES
BUSINESS DEVELOPMENT DIRECTOR
AMERICAS & SOUTH ASIA
ricardo@iptsb.com

TAY KAY LAI
BUSINESS DEVELOPMENT DIRECTOR
ASIA/PAC
tay@iptsb.com

MONICA SEMPERLOTTI
BUSINESS DEVELOPMENT DIRECTOR
EMEA
monica@iptsb.com

INTEGRATED PROCUREMENT TECHNOLOGIES
7230 HOLLISTER AVENUE
GOLETA, CA 93117 USA
P. 805 682 0842 F. 805 682 9434



C-130 CAPABILITIES

BAE SYSTEMS

The ALE-47 Airborne Countermeasures Dispenser System identifies and defeats infrared and radio frequency missiles.

The ALE-47 system uses information from integrated electronic warfare sensors such as radar warning receivers and missile warning receivers to determine the correct response to defeat infrared and radio frequency guided missiles. The cockpit crew has complete control of their threat situation by choosing to operate in any of the four modes: automatic, semiautomatic, manual, and bypass.

BENEFITS

- Combat proven
- More than 3,000 systems installed
- Operating in 30 countries
- Integrates with EW sensors
- Interchangeable with obsolete ALE-40/ALE-39 and M-130 systems
- Uses U.S. and NATO standard and new RF and infrared decoys
- Glass cockpit compatible



COCKPIT DISPLAY UNIT



PROGRAMMER



DISPENSER ASSEMBLY



MAGAZINE ASSEMBLY



SAFETY SWITCH

PART NUMBER	DESCRIPTION	NSN
179720-0001	SWITCH, SAFETY	5930-01-333-2196
179750-0001	DISPENSER	5865-01-334-8349
179740-0002	COCKPIT DISPLAY UNIT	5865-01-380-8046
179730-0005	PROGRAMMER	5865-01-437-3371
179730-0006	PROGRAMMER	5865-01-437-3373
179250-0003	SEQUENCER	5865-01-451-2868
179250-0012	SEQUENCER	5865-01-527-2187

RICARDO FLORES
BUSINESS DEVELOPMENT DIRECTOR
AMERICAS & SOUTH ASIA
ricardo@iptsb.com

TAY KAY LAI
BUSINESS DEVELOPMENT DIRECTOR
ASIA/PAC
tay@iptsb.com

MONICA SEMPERLOTTI
BUSINESS DEVELOPMENT DIRECTOR
EMEA
monica@iptsb.com

INTEGRATED PROCUREMENT TECHNOLOGIES
7230 HOLLISTER AVENUE
GOLETA, CA 93117 USA
P. 805 682 0842 F. 805 682 9434

ALE-47 SUPPORT EQUIPMENT

Countermeasures Dispensing Test Sets (CDTS)

- P/N 188100-7001
- Safety requirement for operational use
 - Stray Voltage Testing
- End-to-End System Testing
 - Suitable for Engineering Lab, System Integration Lab, System Troubleshooting, and Flight Line use



CDTS



MLV

Memory Load Verifier (MLV)

- Loads/Verifies ALE-47 Programmer Software
 - Mission Data File (MDF)
 - Operational Flight Program (OFP)
- MIL-STD-1553 Interface
- Hosted on a Ruggedized COTS computer
 - Suitable for Flightline Use
- Can be combined with TMG on single computer

Threat Matrix Generator (TMG)

- COTS computer configured with BAE Systems proprietary software
- Create and edit Mission Data Files (MDFs) for the ALE-47 Programmer
- Each TMG version supports MDF development for all aircraft with the same ALE-47 Operational Flight Program (OFP)
- Data screens are grouped in a logical manner, promotes ease of use
- Validates values entered are within acceptable ranges

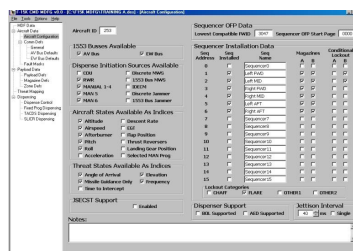

Sample TMG Screens

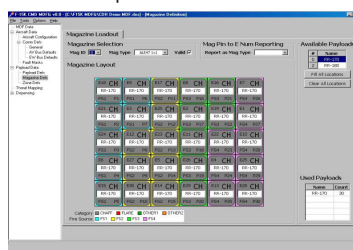

SLTS

Intermediate-Level Tester

I-level tester is the Shop Level Test Set (SLTS)

- Acceptance Testing and Intermediate Level Testing of ALE-47 Electronic LRUs
 - Same Acceptance Test Procedure (ATP) performed at the OEM
- Identifies faults at the Circuit Card Assembly (CCA) level
- New technology refreshed in 2015
- Year over year contracts for international customers ensures upgrades and availability
- Single SLTS can test all ALE-47 LRUs across multiple platform types

Logistics Support

- Direct Commercial Sales (DCS) arrangement recommended
 - Foreign Military Sales (FMS) not required
- Spares can be positioned at end user facilities
- With SLTS, I-level repairs can be performed in-country
- Spares positioned at BAE Systems OEM factory
- Reduced lead time
- Depot repairs at BAE Systems OEM factory

RICARDO FLORES
BUSINESS DEVELOPMENT DIRECTOR
AMERICAS & SOUTH ASIA
ricardo@iptsb.com

TAY KAY LAI
BUSINESS DEVELOPMENT DIRECTOR
ASIA/PAC
tay@iptsb.com

MONICA SEMPERLOTTI
BUSINESS DEVELOPMENT DIRECTOR
EMEA
monica@iptsb.com

INTEGRATED PROCUREMENT TECHNOLOGIES
7230 HOLLISTER AVENUE
GOLETA, CA 93117 USA
P. 805 682 0842 F. 805 682 9434

C-130 LOADMASTER SEAT

Developed as a required crashworthy seat, it is built to protect the loadmaster during harsh landings and other unexpected aircraft mishaps. The BAE Systems C-130 seat is fully repositionable for maximum effectiveness and comfort, and can be equipped with ballistic protection up to NIJ Level IIIA.

KEY FEATURES

- Certified for C-130E, C-130H/H2 H2.5/3 and C-130J/C-130J-30
- USAF TCTO 1C-130-2010
- Energy-absorbing, crash attenuating
- Crash performance verified through extensive dynamic testing
- Accommodates NIJ Level IIIA ballistic protection

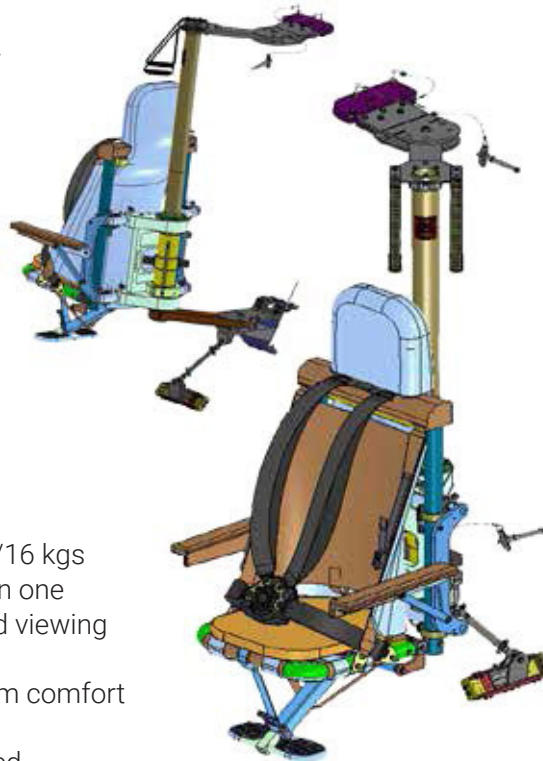

STANDARD FEATURES

- Seat weighs less than 35 lbs/16 kgs
- Can be positioned in less than one minute to various heights and viewing angles
- Designed to provide maximum comfort on long missions
- Seat installed and repositioned within the aircraft in minutes using permanently installed brackets; "No tools required"
- Four-point restraint harness with inertia reel
- Group A hardware mounted permanently to aircraft structure; installed in less than 25 hours per seat, 50 hours per aircraft with no degradation to aircraft structure
- Ergonomically designed to include padded arm rests, head support and foot rests

Lightweight, crashworthy, fixed wing crew seat

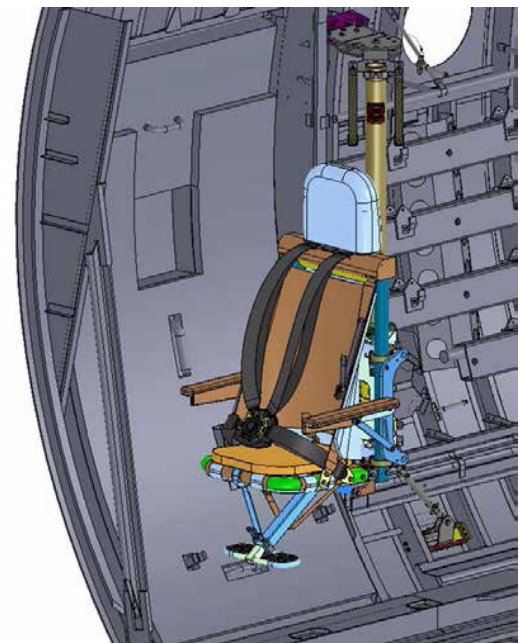

BAE Systems' C-130 Loadmaster Seat is designed to meet a critical need of the United States Air Force.

RICARDO FLORES
BUSINESS DEVELOPMENT DIRECTOR
AMERICAS & SOUTH ASIA
ricardo@iptsb.com

TAY KAY LAI
BUSINESS DEVELOPMENT DIRECTOR
ASIA/PAC
tay@iptsb.com

MONICA SEMPERLOTTI
BUSINESS DEVELOPMENT DIRECTOR
EMEA
monica@iptsb.com

INTEGRATED PROCUREMENT TECHNOLOGIES
7230 HOLLISTER AVENUE
GOLETA, CA 93117 USA
P. 805 682 0842 F. 805 682 9434

AIRCRAFT ARMOR SYSTEMS

Unique and lightweight ceramic, transparent and soft aircraft armor solutions for fixed-wing and rotary-wing aircraft

BAE Systems prides itself on over 30 years of experience in developing and manufacturing lightweight composite armor protection systems for military aircraft. Utilizing our expertise in ceramic composite armor, BAE Systems introduced the first successful military armored crashworthy crew seat for the UH-60 Black Hawk aircraft in 1977.



Monolithic Armored Wing Panel



Monolithic Floor Armor Panel



Monolithic Wall Armor Panel

KEY FEATURES

- Monolithic armor technology accommodates curvatures and saves weight
- Variety of armor systems available to meet specific requirements
- Industry leader in integration and qualification of complex armor systems meeting stringent crash, environmental and impact requirements
- Lightest weight ceramic armor technology available
- Unmatched transparent armor technology

Floor Armor

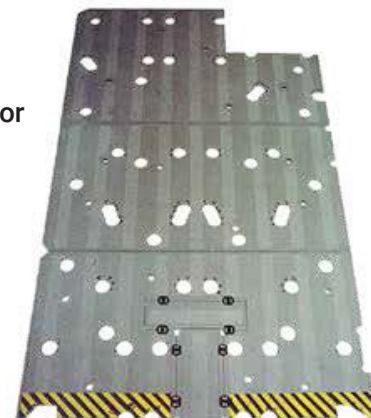

RICARDO FLORES
BUSINESS DEVELOPMENT DIRECTOR
AMERICAS & SOUTH ASIA
ricardo@iptsb.com

TAY KAY LAI
BUSINESS DEVELOPMENT DIRECTOR
ASIA/PAC
tay@iptsb.com

MONICA SEMPERLOTTI
BUSINESS DEVELOPMENT DIRECTOR
EMEA
monica@iptsb.com

INTEGRATED PROCUREMENT TECHNOLOGIES
7230 HOLLISTER AVENUE
GOLETA, CA 93117 USA
P. 805 682 0842 F. 805 682 9434

COMPREHENSIVE DEVELOPMENT CAPABILITIES AND HIGH VOLUME MANUFACTURING

- Armor and composite production areas encompass more than 100,000 sq. ft.
- Work is completed by a team of skilled technicians trained in composite fabrication techniques and specific product requirements
- Armor pre-fit and bonding operations
- In-house ballistic test laboratory
- In-depth understanding of aircraft integration and qualification requirements

TRANSPARENT ARMOR

BAE Systems has developed and patented, and is producing a new liquid-castable transparent polyurethane, Cleargard®*, which provides superior ballistic performance with optimal clarity.

Cleargard's advantages are characterized by:

- Unmatch monolithic performance
- Lower density than acrylic or polycarbonate
- High-impact resistance
- Excellent optical clarity
- High ductility
- High thermal and chemical resistance
- Compatible with a variety of dye packagest and coatings
- Castable to complex shapes or sheet form

STANDARD ARMOR FEATURES

- Lightest weight and lowest areal density (weight per unit area) in the industry
- Defeats Armor Piercing (AP) threats for 7.62 mm and greater calibers
- Complex curvatures, unusual shapes as well as flat components
- Flexibility for hole size and location
- Wide variety of qualified mounting/ attachment methods
- Environmentally tested to MIL-STD-810
- Meets FAR 25 flammability requirements
- Secured for crash and impact loads

MONOLITHIC ARMOR

Our monolithic ceramic technology allows for:

- Minimum amounts for material for reduced weight
- Elimination of raised edges and joints
- Minimized parts counts and costs
- Retained multi-hit performance



THE MONOLITHIC ADVANTAGE IS CLEAR:

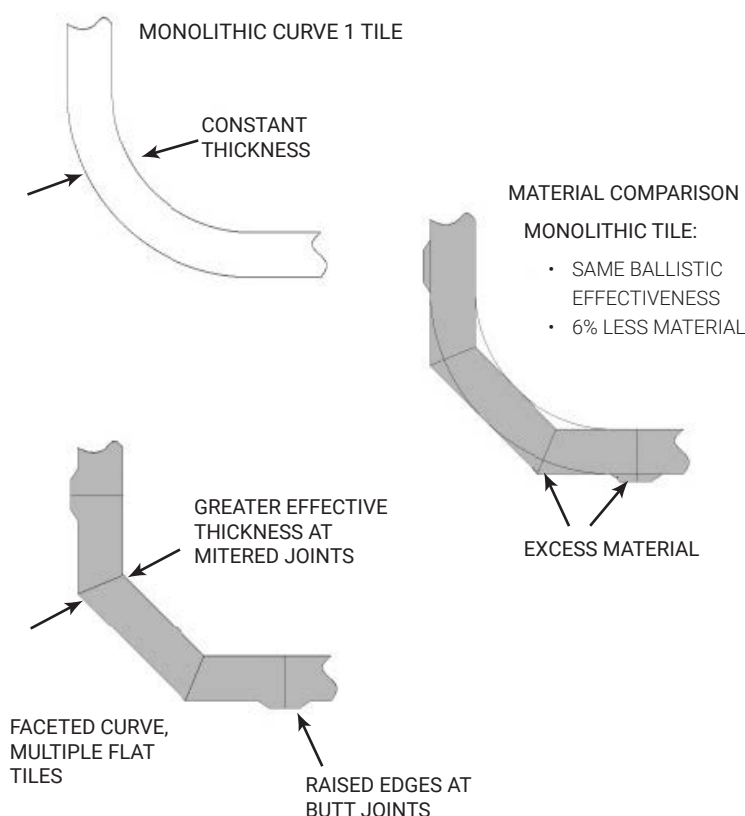

*Cleargard® is a registered trademark of BAE Systems

RICARDO FLORES
BUSINESS DEVELOPMENT DIRECTOR
AMERICAS & SOUTH ASIA
ricardo@iptsb.com

TAY KAY LAI
BUSINESS DEVELOPMENT DIRECTOR
ASIA/PAC
tay@iptsb.com

MONICA SEMPERLOTTI
BUSINESS DEVELOPMENT DIRECTOR
EMEA
monica@iptsb.com

INTEGRATED PROCUREMENT TECHNOLOGIES
7230 HOLLISTER AVENUE
GOLETA, CA 93117 USA
P. 805 682 0842 F. 805 682 9434

WALL STYLE AIRCRAFT TROOP SEAT

IMPROVED SAFETY

BAE Systems' crash resistant troop seat is the first Wall Style Troop Seat to be successfully tested in dynamic crash conditions.*

- 30° nose down surpassing 14 Gs
- 10° yaw surpassing 16 Gs

All fabric meets the FAR 25.853 vertical burn test requirements by utilizing inherently flame-resistant textile materials and flame-retardant treated nylon webbings and tapes.

DURABILITY

Utilizing quality fabrics and developing rugged designs distinguishes BAE Systems and its Wall Style Troop Seat from existing in-service, bench-type seats. High strength aluminum tubing and durable fabric withstands wear and tear and provides superior safety. This provides significant cost reductions in replacement and repair expenses.

OCCUPANT COMFORT

The Wall Style Troop Seat has added comfort by ensuring the occupant's clearance of the seat structure. The seat back is made from a single piece of material designed to minimize equipment snags and provides continuous support.



*Lightweight,
crashworthy,
fixed wing
troop seat*

SEAT WEIGHTS

1-Man: 6 lb (2.8 kg)

2-Man: 10 lb (4.9 kg)

3-Man: 15 lb (7.0 kg)

RICARDO FLORES
BUSINESS DEVELOPMENT DIRECTOR
AMERICAS & SOUTH ASIA
ricardo@iptsb.com

TAY KAY LAI
BUSINESS DEVELOPMENT DIRECTOR
ASIA/PAC
tay@iptsb.com

MONICA SEMPERLOTTI
BUSINESS DEVELOPMENT DIRECTOR
EMEA
monica@iptsb.com

INTEGRATED PROCUREMENT TECHNOLOGIES
7230 HOLLISTER AVENUE
GOLETA, CA 93117 USA
P. 805 682 0842 F. 805 682 9434

Structural Integrity and Seat Comfort for Wall Style Aircraft Troop Seat

Features	MIL-S-5804 Existing Seat	BAE Systems Seat
Interfaces with Existing C-130, C-141 and KC-135 Installation Points	✓	✓
Fabric Assembly Materials Meets FAR 25.853 vertical burn requirement		✓
Eliminates Spreader Bar Contact with Occupant		✓
Improved Spreader Bar Fitting Connection to Aircraft Support Bar Machined aluminum for better durability		✓
Dynamic Strength Verification Dynamic tests performed meet all requirements		✓
Static Testing Test loads applied with contoured anthropomorphic block to highest standards		✓
Seat Back Configuration Seat back is made from the same Aramid material as the seat pan to provide a continuous, durable support surface that does not snag equipment and is adjustable to accommodate a backpack or parachute		✓
Environmental Testing Compliance to MIL-STD-810F		✓
Inter-Seat Fabric Connectors Continuous zipper connection for each seat bottom and seat back connection for added strength		✓
Fabric Connection Fabric attached with machine screws for ease of repair		✓
Floor Fitting Release Easily grasp any part of the leg tube for quick release		✓
Seat Bottom Double layer for improved strength and wear, adjustable to eliminate sag		✓

USAF Performance Requirements**

Configuration	ATD Weight (lb)	Attitude	Velocity (fps)	Deceleration (Gs)	Qualification Test Result
1-Man, 2-Man, 3-Man	250/occupant	30° Pitch Down	35	14	Pass
1-Man, 2-Man, 3-Man	250/occupant	10° Yaw	44	16	Pass

*Testing conducted using 250 lb anthropomorphic test dummies

** Reference USAF Performance Requirements document PD990315

RICARDO FLORES
BUSINESS DEVELOPMENT DIRECTOR
AMERICAS & SOUTH ASIA
ricardo@iptsb.com

TAY KAY LAI
BUSINESS DEVELOPMENT DIRECTOR
ASIA/PAC
tay@iptsb.com

MONICA SEMPERLOTTI
BUSINESS DEVELOPMENT DIRECTOR
EMEA
monica@iptsb.com

INTEGRATED PROCUREMENT TECHNOLOGIES
7230 HOLLISTER AVENUE
GOLETA, CA 93117 USA
P. 805 682 0842 F. 805 682 9434

The AN/ARC-164 standard avionics radio provides the DoD and NATO standard anti-jam UHF voice communications in support of modern military operations.

- 10 watts AM; 25 KHz channel spacing
- Have Quick II ECCM
- Line-of-sight voice
- 2,000 hours demonstrated mean-time-between-failures (MTBF)
- COMSEC/secure speech compatible
- ANVIS Green A front panel lighting and electronic fill port
- Form, fit, function replacement for obsolete UHF radios
- Upgradeable in the field



CONFIGURATION	WIDTH (in)	HEIGHT (in)	DEPTH (in)	WEIGHT (lb)
RT-1504	4.98	4.730	8.32	8.84
RT-1505A	5.75	4.875	8.85	9.25
RT-1518C	5.75	4.875	8.85	9.25
RT-1614*	4.98	4.730	9.11	9.75
C-11718	5.75	4.875	5.44	4.32
MXF-243	5.74	2.980	5.45	3.00

MOUNTING CONFIGURATION	RT-1505A Panel	RT-1518C Panel	RT-1504 Remote	RT-1614 Remote
FREQUENCY RANGE	225.000 to 399.975 MHz			
NO. OF CHANNELS	UHF 7000 (including 20 preset and 1 Guard channel available from panel mount RT and the radio set control).			
MODULATION TYPE	AM			
PRIMARY POWER	R/T Receiver: 35 watts to 16 watts typical Transmitter: 110 watts to 85 watts typical at 24 to 33 Vdc			
CONTROL BOXES	20 watts at 24 to 33 Vdc			
CHANNEL TIME CHANGE	0.25 second maximum in normal mode			
AGC	+5, -4 dB from 4 μ V to 0.5V (all receivers) (1 mV ref)			
SQUELCH	ADJUSTMENT RANGE 0 to 4 μ V minimum			
	HYSTERESIS 2 to 8 dB			
	ATTACK TIME 50 milliseconds maximum			
SELECTIVITY	Narrowband	Wideband		
6 dB	\pm 12 kHz minimum	\pm 35 kHz minimum		
40 dB	\pm 25 kHz maximum			
60 dB		\pm 75 kHz		
AUDIO OUTPUT POWER LEVEL	Normal 200mW Min (Adj)	Wideband		
VOLTAGE LEVEL		2.0 Vrms min		
LOAD IMPEDANCE	150 ohms	500 ohms		
RESPONSE	+1, -3 dB (300 to 3500 Hz)	+3, -5 dB (70 to 25 kHz)		
DISTORTION AT 50% MOD	10% maximum			
VOLTAGE LEVEL	35 dB	No squelch		
VOLTAGE LEVEL	37 dB	Not controlled		

RICARDO FLORES
BUSINESS DEVELOPMENT DIRECTOR
AMERICAS & SOUTH ASIA
ricardo@iptsb.com

TAY KAY LAI
BUSINESS DEVELOPMENT DIRECTOR
ASIA/PAC
tay@iptsb.com

MONICA SEMPERLOTTI
BUSINESS DEVELOPMENT DIRECTOR
EMEA
monica@iptsb.com

INTEGRATED PROCUREMENT TECHNOLOGIES
7230 HOLLISTER AVENUE
GOLETA, CA 93117 USA
P. 805 682 0842 F. 805 682 9434

THE POWER OF PARTNERSHIP



C-130 CAPABILITIES



AIRCRAFT JACKS

MODEL 8704-010
35 TON AXLE JACK
NSN 1730-01-013-4185



AIRCRAFT JACKS - NOSE

MODEL 55A6309
MANIFOLD KIT
NSN 1730-00-594-1730

MODEL 972-018
12 TON TRIPOD JACK
NSN 1730-01-384-1715

MODEL 50J25178
10 TON TRIPOD JACK
NSN 1730-00-516-2019

AIRCRAFT JACKS - WINGS

MODEL 53J6268
30 TON TRIPOD JACK
NSN 1730-00-516-2017

MODEL 8654-010
30 TON TRIPOD JACK
NSN 1730-01-068-1126

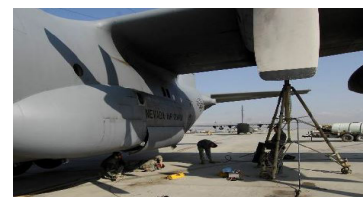

JACK TESTERS

MODEL 7054-020
PORTABLE JACK TESTER

MODEL 7186-010
STATIONARY JACK TESTER
NSN 1730-01-329-6355

BEAD BREAKERS

MODEL 9323-020
30 TON CAPACITY
NSN 4910-00-267-9126

MODEL 715J1000EX
25,200 LBS CAPACITY
NSN 4910-01-267-7191



RECOVERY SYSTEMS

MODEL 48C7171
11 TON PNEUMATIC LIFTING BAG
NSN 1730-00-263-2962

WHEEL DOLLY

MODEL 9764-010
800 LBS CAPACITY
NSN 1730-00-529-8231



RICARDO FLORES
BUSINESS DEVELOPMENT DIRECTOR
AMERICAS & SOUTH ASIA
ricardo@iptsb.com

TAY KAY LAI
BUSINESS DEVELOPMENT DIRECTOR
ASIA/PAC
tay@iptsb.com

MONICA SEMPERLOTTI
BUSINESS DEVELOPMENT DIRECTOR
EMEA
monica@iptsb.com

INTEGRATED PROCUREMENT TECHNOLOGIES
7230 HOLLISTER AVENUE
GOLETA, CA 93117 USA
P. 805 682 0842 F. 805 682 9434

THE POWER OF PARTNERSHIP

C-130 CAPABILITIES

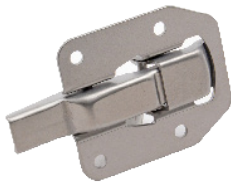

TRIGGER LOCK

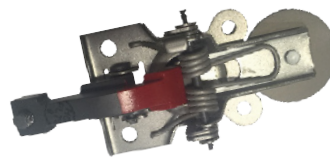

PUSH BUTTON LATCH

P/N	DESCRIPTION	NSN
118015	HOUSING ASSEMBLY,EN	1560-00-628-4733
118019	TOGGLE ASSY,ENGINE	1560-00-628-4732
H122-4	LATCH,RIM	5340-00-807-9009
H2454-11	LEVER, LOCK RELEASE	
H2454-13	STRIKE,CATCH	5340-01-324-2022
H5000-2-032-081	CATCH,FLUSH	5340-00-598-2851
H5000-2-040-081	CATCH,FLUSH	5340-00-598-2851
H5000-2-040-091	CATCH,FLUSH	5340-00-530-7642
H5000-2-051-156	CATCH,FLUSH	5340-00-209-9298
H5000-2-064-115	CATCH,FLUSH	5340-00-514-3073
H5000-2-064-125	CATCH,FLUSH	5340-00-205-6914
H5000-2-072-164	CATCH,FLUSH	5340-01-471-8540
H5000-2-102-115	CATCH,FLUSH	5340-00-616-5841
H5000-2-102-132	CATCH,FLUSH	5340-00-026-4574
H5000-2-102-340	CATCH,FLUSH	5340-00-184-8406
H5000-3-032-081	LATCH	
H5000-3-040-081	LATCH ASSEMBLY,AIRCRAFT	1560-01-521-4047
H5000-3-040-091	CATCH,FLUSH	5340-01-491-8861

P/N	DESCRIPTION	NSN
H5000-3-051-096	LATCH,MORTISE	5340-01-660-8623
H5000-3-051-102	CATCH,FLUSH	5340-01-448-3329
H5000-3-051-115	CATCH,FLUSH	5340-01-436-4237
H5000-3-064-096	LATCH ASSEMBLY,AIRCRAFT	1560-01-561-0564
H5000-3-064-115	CATCH,FLUSH	5340-01-435-3023
H5000-3-064-125	LATCH ASSEMBLY,AIRCRAFT	1560-01-563-8159
H5000-3-125-179	LOCK TRIGGER	
H5000-3-188-340	GUARD,TRIGGER	1005-01-477-1696
H5010-051-091	CATCH,FLUSH	5340-00-865-0531
H5010-051-179	CATCH,FLUSH	5340-00-794-8266
H5010-051-203	CATCH,FLUSH	5340-00-794-8265
H5010-064-164	CATCH,FLUSH	5340-00-673-6177
H5040A064-375	LATCH ASSEMBLY	5342-00-529-6101
H600S050A091	LATCH ASSY,PUSH BUT	5342-00-335-9084
H600S063A153	CATCH,FLUSH	5340-00-234-7866
H600S063A181	CATCH,FLUSH	5340-01-470-7300
H600S190A471	LATCH SET,RIM	5340-00-460-4698
HA197-1	LATCH ASSY	

RICARDO FLORES
BUSINESS DEVELOPMENT DIRECTOR
AMERICAS & SOUTH ASIA
ricardo@iptsb.com

TAY KAY LAI
BUSINESS DEVELOPMENT DIRECTOR
ASIA/PAC
tay@iptsb.com

MONICA SEMPERLOTTI
BUSINESS DEVELOPMENT DIRECTOR
EMEA
monica@iptsb.com

INTEGRATED PROCUREMENT TECHNOLOGIES
7230 HOLLISTER AVENUE
GOLETA, CA 93117 USA
P. 805 682 0842 F. 805 682 9434

C-130 CAPABILITIES



Avionic Instruments
Aerospace for Industry

REGULATED TRANSFORMER RECTIFIER UNIT MODEL NO. RTR11200-1A

P/N 1-002-0102-2381
NSN 6130-01-521-2734

- All the benefits of traditional unregulated TRUs with the added feature of precise output voltage regulation
- Standard product line to include 120A, 200A, 300A and 400A units
- Provides continued unregulated performance in the event of an internal regulating failure
- Input power factor stability over the entire load range, minimal reflected input current harmonics, and high efficiency
- Parallel capability for higher power requirements
- Point of regulation capability allows the RTR to be used in battery charging applications



AEROVAC FREQUENCY CONVERTER MODEL NO. 4C3500-1A-MV-2147

P/N 1-002-0102-2147
NSN 6130-01-608-3143

- Power levels ranging from 1KVA through 52.5KVA
- Converts aircraft standard 400 Hz three phase to 115VAC 60 Hz or 230VAC 50 Hz power
- Same patented output bridge switching control topology as AI2 Static Inverter design
- 12 Pulse input rectification ensures generator compatibility
- Near unity input power factor
- Latest products provide 3.5KVA at less than 25 lbs



STATIC INVERTERS

P/N 1-002-0102-2044	P/N 1-002-0102-2075	P/N 1-002-0102-2381
NSN 6130-01-521-2734	NSN 5905-01-649-9658	NSN 5905-01-649-9658

- Power levels ranging from 20VA through 37.5KVA
- Output configurations: 115, 230VAC; 50, 60 & 400 Hz, single and three phase
- Advanced high frequency switching topology with patented form of Hysteretic Current Mode Control
- True sinewave output with excellent non-linear load handling capability
- Products meet FAA/CAA requirements



RICARDO FLORES
BUSINESS DEVELOPMENT DIRECTOR
AMERICAS & SOUTH ASIA
ricardo@iptsb.com

TAY KAY LAI
BUSINESS DEVELOPMENT DIRECTOR
ASIA/PAC
tay@iptsb.com

MONICA SEMPERLOTTI
BUSINESS DEVELOPMENT DIRECTOR
EMEA
monica@iptsb.com

INTEGRATED PROCUREMENT TECHNOLOGIES
7230 HOLLISTER AVENUE
GOLETA, CA 93117 USA
P. 805 682 0842 F. 805 682 9434



**FREQUENCY CONVERTER
MODEL NO. 4H3500-1A-2499**

P/N 1-002-0102-2499

•The Avionic Instruments Product is a 3.5KVA Frequency Converter:

Converts 3-phase, 115VAC L-N, 320Hz - 600Hz to single phase, 115VAC, 60Hz for the purpose of powering AC outlets.

•P/N 1-002-0102-2499 is identified as a replacement for the following Frequency Converter part numbers currently installed on C-130J under NSN: 6130-01-598-6011:

P/N: 717220-1

P/N: 717220-2

P/N: 717220-2R



PRODUCT SPECIFICATIONS

Features

Input Voltage	115/200VAC, 3-Phase WYE, Nominal 108 - 118 VAC L-N, Normal. Pwr interruptions as per Mil-Std-704E
Input Frequency	320 - 800Hz
Input Current	12.5A typical; 15A per phase, max, for rated load & nominal input. Input total harmonics distortion <5%
Input Power Factor	Not less than 0.9, lagging and \leq unity from half to full load
Output Voltage	115VAC +/- 3VAC, single phase, for normal input range, no load to full load over the full temperature range. Transients per Mil-Std-704E
Output Frequency	60 +/- 0.6 Hz
Output Power	3500 VA, nominal
Output Waveshape 5.0% max, normal operation	1.5% THD, typical
Output Power Factor Not damaged by any power factor	0.75 lag to 0.8 lead
Efficiency	87% typical
Overload 5250VA for 5 minutes	3850VA for 2 hours
Protections Output over/under frequency; Overtemperature Short Circuit; Input over/undervoltage	Output overvoltage
Environmental	RTCA DO-160G
Mechanical	17L" X 7W" X 5H" 23.5 lbs, max
Features	Remote On/Off

RICARDO FLORES
BUSINESS DEVELOPMENT DIRECTOR
AMERICAS & SOUTH ASIA
ricardo@iptsb.com

TAY KAY LAI
BUSINESS DEVELOPMENT DIRECTOR
ASIA/PAC
tay@iptsb.com

MONICA SEMPERLOTTI
BUSINESS DEVELOPMENT DIRECTOR
EMEA
monica@iptsb.com

INTEGRATED PROCUREMENT TECHNOLOGIES
7230 HOLLISTER AVENUE
GOLETA, CA 93117 USA
P. 805 682 0842 F. 805 682 9434

C-130 CAPABILITIES



VIPER-2E 4-CHANNEL ANALYZER

The VIPER-2E is a versatile yet compact instrument that combines all of the diverse technologies required for high-end engine vibration analysis, transient balance, fan trim balance, propeller balance and acoustic analysis into one tool. All of these maintenance functions can be easily performed on virtually any airframe and/or engine type using the VIPER-2E.



1. TRANSIENT VIBRATION ANALYSIS

Accurate High-Speed Run-up and Coast-Down Transient Surveys

2. TRANSIENT BALANCE

Save Time and Money by Collecting Data in a Single Sweep

3. MIL-SPEC DESIGN

Ensure Reliability of Measurements in Harsh Environments

FEATURES

- Transient Balance yields test cell quality balancing results
- Direct PDF report generation onto a USB flash drive
- .CSV export of raw data for further analysis
- SmartTach speed and phase processing allows direct measurement of the engine speed signal
- Four-channel simultaneous data acquisition for speed and accuracy
- Supports inputs for (4) Vibration Channels, (4) Mag P/U or Optical Tach Inputs, (1) TraX Optical Tracker, and (1) Strobe
- USB port for direct connection to peripherals
- Housed in ZERO case for maximum environmental protection
- 1-year warranty plan for defects of components and workmanship

RICARDO FLORES
BUSINESS DEVELOPMENT DIRECTOR
AMERICAS & SOUTH ASIA
ricardo@iptsb.com

TAY KAY LAI
BUSINESS DEVELOPMENT DIRECTOR
ASIA/PAC
tay@iptsb.com

MONICA SEMPERLOTTI
BUSINESS DEVELOPMENT DIRECTOR
EMEA
monica@iptsb.com

INTEGRATED PROCUREMENT TECHNOLOGIES
7230 HOLLISTER AVENUE
GOLETA, CA 93117 USA
P. 805 682 0842 F. 805 682 9434